



## Packaging Solutions for over 40 Years

Rennco manufactures a full line of vertical packaging machinery and automated systems that create flexible packages and bags to suit your products and needs. Since 1969, companies around the world have depended on Rennco's bagging solutions to package a wide variety of products. Rennco's fast, easy-to-use form, fill, and seal systems produce packages on the Vertic-L-PP Systems up to 18"x 24", without the high cost of using pre-made bags.

### Rennco Advantage

Rennco's versatile machines deliver year-after-year reliability and value that simply can not be matched by other vertical baggers or options using pre-made bags. Here is the Rennco advantage:

- **Experience.** More than 5,000 packaging equipment solutions delivered to more than 1,400 customers in 47 countries.
- **Expertise.** Rennco engineering and technical support team excels at solving packaging challenges.
- **Support.** One of the leading reasons for Rennco's many repeat customers. Rennco stands behind all of their solutions with courteous, responsive customer support and comprehensive aftermarket services and parts. Rennco is also a division of Pro Mach, one of the largest designers and manufacturers of packaging equipment.
- **Reliability.** Heavy-duty construction and design provides reliable service 24/7, year after year.
- **Innovation.** Rennco's innovative low energy and constant-coated seal system provides smokeless, odorless package sealing with less material buildup. The uptime seal-jaw assembly provides precise tool-less adjustment, consistent repositioning and improved performance.
- **Value.** Small footprint, high efficiency, and savings on material cost over pre-made bags provide years of value and low total cost of ownership.



## Versatile, Reliable, Cost-effective Automation

### Sample applications:

Bar Towels

Shop Rags

Garments

Wash Cloths

Hand Towels

Knit Sheets

Hospital Gowns

Towel Sets

Sheet Sets

## Technical Support and Service

- **Installation and Start Up of New Equipment.** Experienced Rennco technicians provide assistance in setting up and testing in your plant to ensure all production expectations are met.
- **PMMI Certified Training.** We train your personnel in your plant on your equipment
- **Follow-Up Training.** Our technicians are available any time after the initial installation for follow-up training for new employees or to provide new information and techniques.
- **Machine Repair and Service.** Rennco technicians provide timely repair assistance and general machine service. They offer equipment evaluations, assistance in achieving maximum production rates, and recommendations for upgrades and maintenance schedules.
- **Refurbishing Packagers or Entire Systems.** Cost effective and warranted factory refurbishing is available for most Rennco equipment.



## After-Market Customer Services

- **Competent Phone Service.** Trouble shooting support for everything from mechanical adjustments to electrical controls, PLC programming, and recommended maintenance. Contact us at 800.701.1343.
- **Parts Sales.** Rennco takes pride in our responsive and supportive parts department. Most orders are shipped the same day and arrive at your door the next day, if required.
- **After Hours Support.** Call 517.449.8901 after 5 pm ET to speak with a service technician.



PO Box 116  
300 Elm St.  
Homer, MI 49245  
USA  
www.Rennco.com

Toll-Free: 800.409.5225  
International: 517.568.4121  
Fax: 517.568.4798  
Email: sales@rennco.com



## Packaging Systems for the Laundry Industry

Your product. Your budget. Your needs.

powered by Pro Mach

# Packaging solutions designed to meet your needs and product requirements

## Model **V**ertic-L-PP SYSTEM



## Model **V**ertic-L-PP **D**ual **S**YSTEM



Interface panel shows correct product count.

## Model **S**hrink **B**UNDLER



### Advantages

- Vertical film roll placement of centerfolded material for ease of roll change
- Produces trimless packages thus eliminating the need for a trim/scrap rewind system
- Increased efficiency with tool-less changeovers
- Maximum bag size capability 18" x 24"
- User-friendly HMI screen for setting selections
- Automatic machine cycling with light curtain mechanism
- Significant cost savings over pre-made bags
- Easily interfaced with infeed systems
- Bag tapper assists with distribution of products in the package

### Option

- Weigh scale add-on available for faster alternative to counting

### Specifications

Standard Horizontal Seal	24"
Standard Vertical Seal	18"
Standard Jaw Opening	9½"
<b>Electric Requirements</b>	
Vertic-L-PP	120 V, 60 HZ, 1 ph, 15 amps
Vertic-L-PP Dual	120 V, 60 HZ, 1 ph, 20 amps
Air Requirements	.6 CFM 80 PSI

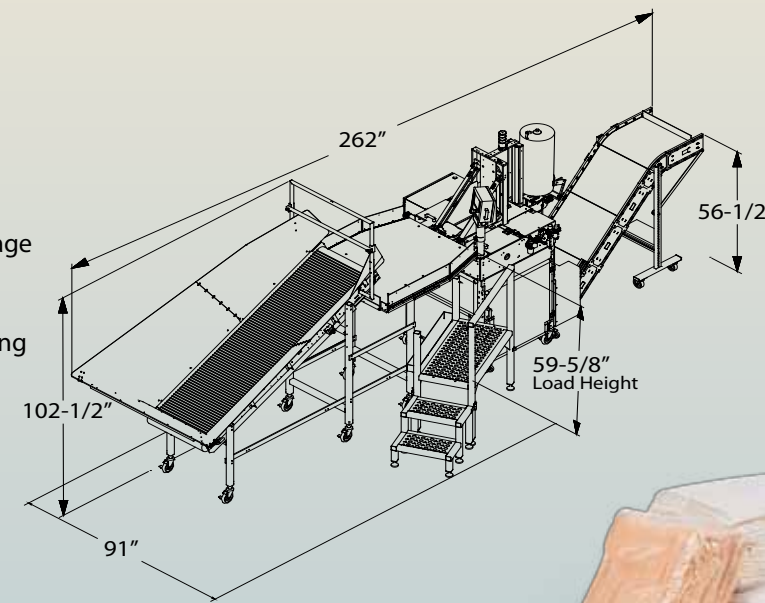

### Dual System Advantages

- Dual Output
- Increased efficiency with (1) hopper area, (2) operator loading areas & (2) seal systems

### Option

- Weigh scale add-on available for faster alternative to counting

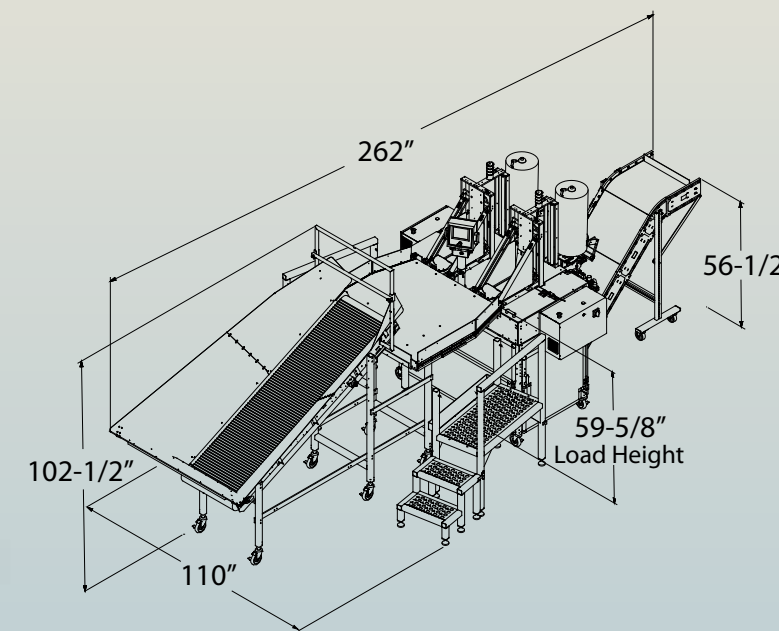

### Advantages

- Features a 30" long Rennco Tri Bar seal system as standard equipment
- Designed as an economical, automatic solution for a variety of packaging operations
- Infeed and discharge conveyors are automatically operated to sequence the delivery of each package through the curtain of film, stopping for the desired seal position, then delivering the package to a separate shrink tunnel

### Specifications

Horizontal Seal Width	30"
Maximum Jaw Opening	14"
Belt Speed	40 ft/min.
Electrical Requirements	120 V, 60 HZ, 1 ph 10 amps
Air Requirements	.2 CFM 80 PSI

