

NEW for 2010

FA Turntable Automatic Stretch Wrapping System



Performance Features

- Category 2 safety rating
- Surround wire mesh fence
- Light curtains with muting
- Allen Bradley MicroLogix 1400 PLC
- Built-in ethernet capability
- External PLC com port
- External 115V power outlet
- Conveyor rollers on 3.25" centers
- Independent carriage up/down speed
- AC Motors with Allen Bradley Powerflex VFD
- Heavy duty chain & sprocket turntable drive
- Ergonomic side facing carriage for easy film load
- Automatic film force-to-load control
- Structural & formed steel for maximum durability
- Long lasting powder coat paint finish
- Air knife eliminates hanging film tail
- 260% Insta-Thread prestretch



New & Improved



Orion FA Standards	
Turntable & Load	
Turntable RPM	1 - 15 RPM
Maximum Load Weight	4,000 lbs.
Maximum Load Size	48"W x 48"L x 80"H
Minimum Load Size	30"W x 30"L x 15"H
Conveyors	
Elite Conveyors – Base System	1 Infeed, Turntable, 1 Exit
Conveyor Types	Powered Chain Driven Roller
Roller Diameter & Centers	2.5" Diameter Rollers on 3.25" Centers
Pass Height	18" from Floor
Speed	30 FPM with Soft-Start
Control	Allen Bradley Power Flex Variable Frequency Drives
Floor Support	Steel Channels with Slotted Adjustment & Pivoting Feet
Controls & Drives	
PLC Controller	Allen Bradley MicroLogix 1400 w/Ethernet and two Serial Communication Ports
Control Panel HMI	Telemecanique Magelis® 5.7" Color
Motors	AC Motors with Allen-Bradley Power Flex VFD's
NEMA Rating	NEMA 12
Safety Rating	Category 2
Film & Carriage	
Film Width - Film Carriage	20"
Film PreStretch	260%
Film Tail Containment	Pneumatic, Fold-Away with Air Blower
Film Tail Treatment	Hot-Wire Film Severance with Pneumatic Wipe-Down Loop
Independent Carriage Up/Down Controls	Variable Speed Up & Down
Independent Top/Bottom Wrap Counts	1 to 9 Wraps Available
Structure & Finish	
Base Frame	Structural Steel Tubing
Film Mast	Structural Steel Tubing
Finish	Baked On Powder Coat Paint
Utilities	
Standard Voltage	480/3/60 (4 Wire w 3 Lines Ground) 30 AMP
Air Requirements	80 PSI @ 6 CFM
Warranty	
Components	3 Years
Structural Frame	5 Years
PreStretch Rollers	Lifetime

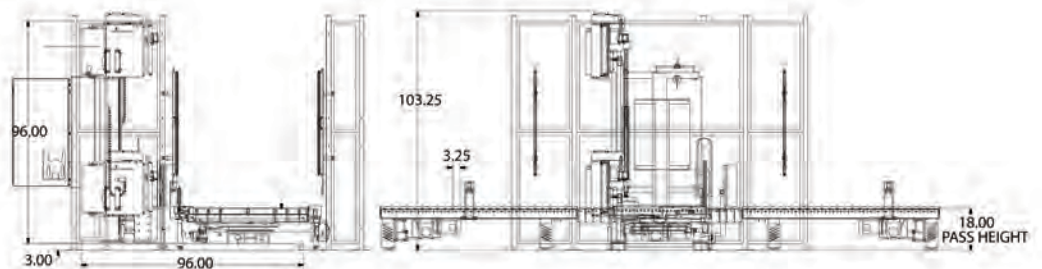
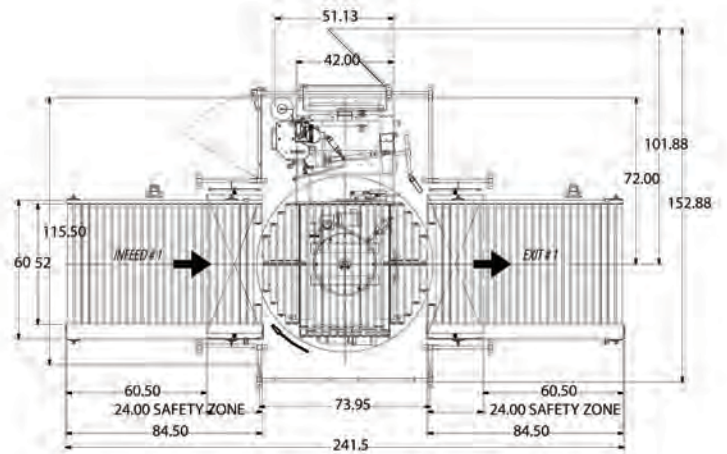

(800) 333-6556
 orionpackaging.com