

VERTIC•L™

Semi-Automatic Vertical L Bar Bagger

Rennco™
World-Class Packaging Solutions
a division of Pro Mach

Advantages

- Flat roll stock material offers cost savings over pre-made bag operations
- Versatile design produces package sizes up to 14" x 14"
- Small footprint for easy portability
- Increased efficiency with tool-less changeovers
- Trim pull device manages trim to save time changing roll stock and reduce line interruption
- User-friendly HMI screen for setting selections
- Automatic machine cycling with light curtain mechanism

Description

Rennco's **new small footprint vertical bagging solution provides a reliable, versatile cost-effective** alternative to pre-made bags for a wide variety of common and unusual shaped items. Rennco stands behind the Vertic•L with a 40-year tradition of innovation, experience and industry leading customer service and support.



Sustainable Bagging

The Vertic•L is a versatile, cost effective bagger utilizing flat stock material versus pre-made bags. Customers receive a bag similar in appearance to retail bagging efforts at a fraction of the cost. The Vertic•L offers cost-cutting and sustainability opportunities through lower cost of labor and material.



The Vertic•L bags a wide variety of products quickly and easily

Simply load product through the light curtain area...

...Once your hand retracts, the light curtain automatically initiates the machine cycle...

...Bagged product exits down the chute while operator prepares next item for bagging. That's all there is to it!



User-friendly HMI

Control panel buttons allow the operator to easily change machine settings. Bag length, seal bar temperatures, and setup features are all easily adjusted. It also monitors run cycle and lifetime cycles.

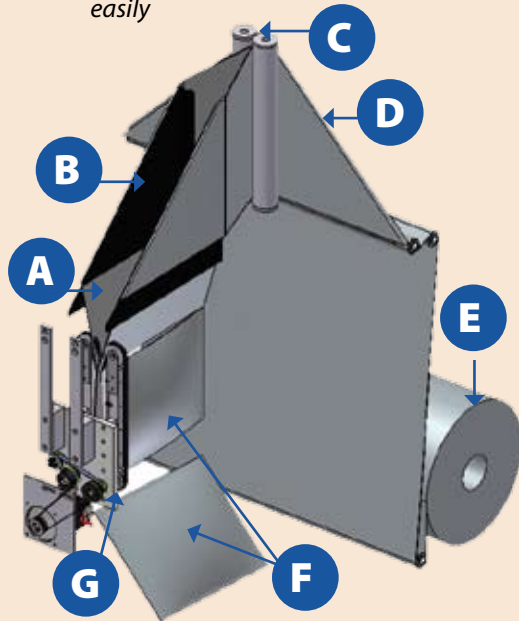

Vertic•L Features

- A. Load Product** Simply hand place product between light curtains
- B. Adjustable Spreader Chute** Allows for easy loading of products into packaging film
- C. Folding Rollers** Guides folded material
- D. Folding Plate** Folds material from flat to centerfold
- E. Roll Stock Material** Utilizes flat stock material
- F. Finished Package** Appearance comparable to retail bagging efforts
- G. Film Puller** Pulls scrap down and away from package

Specifications

Standard Vertical Seal	14"
Standard Horizontal Seal	14"
Standard Jaw Opening	4"
Electrical Requirements	110V, 60hz, 1 ph 15amps*
Air Requirements	.12 CFM at 80 PSI

*Special electrics available upon request.

Contact us for the free whitepaper "vertical bagging machines offer cost cutting opportunities"

Annual Cost Savings Over Pre-made Bags*

Running	vs. Poly bags (Based on \$5.00/lb.)	vs. Roll bags (Based on \$5.68/lb.)
10 bags/min	\$5,746	\$6,846
30 bags/min	\$17,279	\$20,588

* 3" x 5" bag size, .001 Mil Polyethylene & \$1.45/lb.

Dimensions

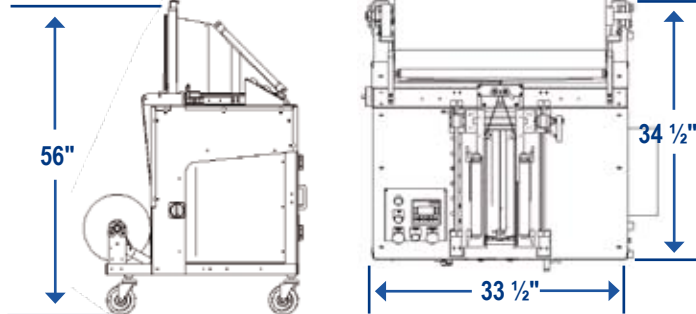

Distributed by:

RenncoTM
World-Class Packaging Solutions
a division of Pro Mach

PO Box 116
300 Elm St.
Homer, MI 49245
USA
www.Rennco.com

Toll-Free: 800-409-5225
International: 517-568-4121
Fax: 517-568-4798
Email: sales@rennco.com

(Rev 060310)